

CI/SfB	(29)	(k2)
CAW P10		
Uniclass JP10:L68114		

Product Information

Description

FS719 HP Blue for CPVC is a unique sealant developed specifically for CPVC materials.

The product has a distinctive blue colour for easy visual identification and traceability. FS719 is a powerful product, designed to close CPVC, only when the pipes are deteriorating under fire conditions. Approved for use by a CPVC pipe manufacturer, and registered as such for use around Flowguard, Blazemaster, Corzan, etc.

This advance product has been made available to installers of fire protection and sprinkler systems. Tremco CPG UK Ltd should be contacted for technical advice and installation recommendations when used with other CPVC pipe types.

Usage / Purpose

FS719 is used to reinstate the fire performance of compartment lines (walls & floors) which have been breached by CPVC combustible sprinkler systems or other CPVC systems.

The product remains inert until exposed to a specific temperature. At this point FS719 will expand and seal the gap left by the dysfunctional CPVC sprinkler pipe. Tested for use around 1", 2" and 3" Internal Diameter CPVC pipes through flexible & rigid walls and rigid floors. FS719 may be used direct within substrate (plasterboard, blockwork, concrete) or within FB750 Intubatt when installed in full accordance with our testing methods and recommendations.

Colour

Blue

Packaging

310 ml cartridges (25 per box)

Availability

Direct from Tremco CPG UK Limited (see details on this TDS).

Usage Guidelines

Always read SDS, pre-application guidance and relevant application detail prior to application. Ensure the latest documents are downloaded prior to

every project commencement.

Protective Equipment

Use in well ventilated conditions and ensure all recommended protective equipment is worn during handling & use of this product. For full recommendation, refer to safety data sheet.

Necessary Tools

- Sealant caulking gun
- Sealant profiling tool/spatula

Preparation

- All installers should have received training on the correct handling procedures required by the manufacturers of CPVC pipes on their products.
- All surfaces must be clean and sound, free from dirt, grease and any other contamination. Cleaning materials used must be approved & recommended by the CPVC pipes manufacturer.
- Check FS719 specification is suitable for substrate, fire rating, annular space and seal depth.
- We recommend that the surface of substrate temperature be +5°C or above at the time of application. Contact Technical Services for advice regarding lower temperature application.

Application

- Insert required backing material (foamed polyolefin - polyethylene non-oiled- or rock mineral wool, as per application instructions), oversized to opening to ensure stability, to provide correct depth of seal.
- Using a suitable tool, open cartridge and cut nozzle of cartridge to bead size and angle required.
- Gun sealant into gap to required depth by applying an even pressure to the trigger.
- Work and tool to a smooth finish immediately with a wet profiling tool or spatula.

Important Information

- This product is tested for use only around CPVC pipes.
- The product may function on other pipe types, but is not tested for such materials and should not be used as a general fire stopping product.
- Sprinkler system design must include allowances for CPVC thermal expansion

Nullifire

Smart Protection

FS719

HP Blue for CPVC



FBC
SYSTEM COMPATIBLE



Key Benefits Summary

- Up to 120 minutes fire resistance - Tested to EN 1366-3
- Versatile & easy to apply
- Can be used with FB750 Intubatt Coated Batt
- Easily identifiable



FS719 HP Blue for CPVC

at the point of interface with FS719. If this has not been considered, we recommend a foil barrier extending through the compartment as a slip joint between the CPVC pipe and the FS719.

- The sprinkler system must be installed in full accordance with all manufacturers' recommendations and storage condition guidance. The design of the sprinkler system should consider all local heat sources (close to the sprinkler system), other services (should be prevented from touching the sprinkler system), and building deflection that may have a long term detrimental effect and cause stress fractures on the sprinkler system if not considered in the design.
- FF197 Fire Rated PU Foam may not be used as a backer material with FS719 around CPVC pipes.
- The materials recommended on this TDS are as approved by Lubrizol and are correct as of the day of publication.
- When used within FB750, care should be taken to avoid any contact with any other sealant type required for application from coming into contact with CPVC.

Typical Details

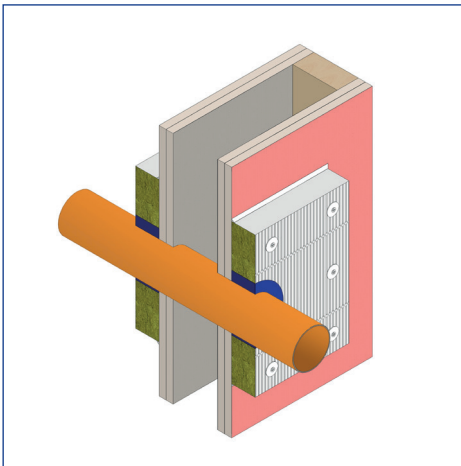

FB750 double batt pattern fit + FS719 HP Blue seal

Coverage

To determine quantity of sealant required, calculate as following example (in mm):

$$\frac{\text{Gap Width} \times \text{Depth} \times \text{Total Length}}{310} = \text{N}^\circ \text{ of cartridges}$$

For further guidance on application methods, and material requirements, please contact Tremco CPG UK Limited Technical Services Department.

Maintenance

No maintenance required after installation. Routine inspection recommended to ensure no damage.

Health & Safety Precautions

Safety data sheet must be read and understood before use.

Technical Service

Tremco CPG UK Limited has a team of experienced Technical Sales Representatives who provide assistance in the selection and specification of products. For more detailed information, service and advice, please call Customer Services on +44 (0)1942 251400.

Guarantee / Warranty

Tremco CPG UK Limited products are manufactured to rigid standards of quality. Any product which has been applied (a) in accordance with Tremco CPG UK Limited written instructions and (b) in any application recommended by Tremco CPG UK Limited, but which is proved to be defective, will be replaced free of charge.

No liability can be accepted for the information provided in this leaflet although it is published in good faith and believed to be correct.

Tremco CPG UK Limited reserves the right to alter product specifications without prior notice, in line with Company policy of continuous development and improvement.

Additional Notes

FBC™ System Compatible indicates that this product has been tested, and is monitored on an ongoing basis, to assure its chemical compatibility with FlowGuard Gold®, BlazeMaster® and Corzan® piping systems and products made with TempRite® Technology. FBC™, FlowGuard Gold®, BlazeMaster®, Corzan®, and TempRite® are trademarks of The Lubrizol Corporation or its affiliates.

Technical information

Property	Test Method	Result
Composition		Water based graphite sealant
Specific Gravity		1.33
Viscosity		Thixotropic
Hardness Shore A		~ 80
Skin Formation Time		40- 60 minutes depending on temperature & humidity
Cure Rate	at 20°C	1 mm/day
Application Temperature		+5°C to 35°C
Storage		Store in shaded dry conditions between +5°C and +35°C
Shelf Life		9 months when stored as recommended in original unopened containers