

Linoleum xfTM₂

SD, Conductive

Linoleum floors

September 2015

Linoleum Static Dissipative SD xf²

Linoleum Conductive xf²

IMPORTANT!

- Make sure all specifications and instructions are followed carefully.
- Contact your Tarkett representative if you are unsure about any part of the installation.
This information is subject to change due to continuous improvement.
Use tools dedicated to linoleum installation (wall scribe, linoleum hammer for joints, joint scribe, edge trimmer...)
- Use the same batch number for each continuous surface, installing the rolls in sequential order number.
- Caution: always check the length of linoleum rolls.
- Store the rolls upright, in a safe position, in a dry place, protected from heat and cold, moisture, rust and rot, free from any contamination and not piled up or crushed under a heavy weight.
- Let the flooring acclimatise at least 24h before laying at room temperature (minimum 18°C).
- The subfloor must be flat, level, clean, without marks (no felt pen, marker, etc.), sound, dry, solid, hard, smooth and not exposed to moisture. Absorbency must be checked and adjusted to have moderately absorbent subfloor.
- Use only adhesives recommended by Tarkett. Always follow the adhesive manufacturer's instructions.
- The work must be completed with an inspection: ensure that the newly laid floor is free from adhesive residues.
- **Do not treat the flooring with wax or polish, such treatment may change the products conductive behavior.**

SUBFLOOR

The subfloor must be level, flat, clean, free from marks (no felt pen, marker of any type, ballpoint pens, paint, etc., that could cause discoloration due to migration) sound, dry, solid, hard, smooth (the absorbency must be checked) and not exposed to moisture.

The preparation/dryness of the subfloor and installation procedures should all be in accordance with the current relevant Standard within the country of use. The dryness of a solid subfloor should be below the maximum moisture level permitted when tested in accordance with that Standard.

E.g. in the UK, the relative humidity of concrete surfaces must be below 75%, and less than 2% with the CCM method.

In North America, ASTM F-170 recommends a water-to-cement ratio of 0.40 to 0.45.

Before selecting a smoothing compound, check what type of traffic the floorcovering will be subjected to once installed. Latex smoothing compounds are not suitable for areas that will receive heavy traffic, especially heavy, narrow wheeled traffic (see EN 12529, Castors and wheels). Check levelling compound compatibility, and follow the instructions of the levelling compound manufacturer.

Note: exclusion of liability (adhesives, levelling compounds, etc.)

Although Tarkett may list a selection of adhesive, levelling compound and surface damp-proof membrane manufacturers and types, we do not guarantee the products listed. The list of products and manufacturers is not guaranteed complete or current.

Tarkett will accept no liability for any of these products failing to perform in conjunction with any of its products. It is the responsibility of the adhesive, levelling compound and surface damp-proof membrane manufacturer and flooring contractor to ensure the products being used are appropriate for use and applied in accordance with the manufacturers' recommendations.

If any doubts or clarifications should be needed, please contact your local Tarkett representative for further information.

CONDITIONS REQUIRED FOR INSTALLATION

It is important that sheets are stored at least 24 hours before installation at a minimum room temperature of 18°C. This temperature should be maintained throughout the installation.

The minimum temperature of the subfloor should be 15°C.

The recommended relative humidity in the room is 35-65%.

Sections of flooring must be cut to the required lengths, plus an allowance of a few centimetres, and stored in the room where they are to be installed. Don't roll the linoleum with the jute outside.

EARTH CONNECTION

The earth connection is reached using a copper strip.

Place the copper strip on the subfloor following these rules

Surface < 20 m²:

Place the copper strip at only one of the short end.

Surface 20-40 m²:

Apply a copper strips crossways under the sheets, 200 mm from the short ends. A 100 cm copper strip is placed lengthways under transverse joints.

Surface > 40 m²:

Apply copper strips crossways at the short ends and at every 20 metres. A 100 cm copper strip is placed lengthways Under transverse joints.

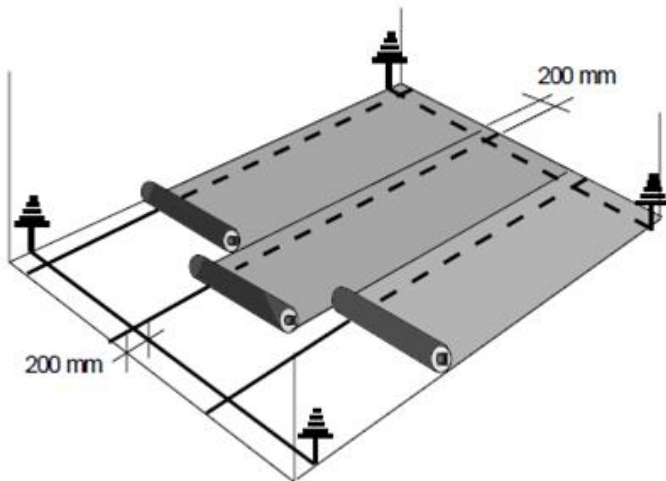

LAYING DIRECTION

At least 24 hours before installation, the material should be cut to the desired lengths; the cut sheets must be acclimatised where they are to be installed by placing them in an upright position.

Plan the sheet direction for the area to be installed to ensure that whenever possible joints do not coincide with doorways, main traffic lanes, sinks or urinals.

If the room is reasonably square, the sheets should run parallel to the incoming light.

In long, narrow rooms it is best to install the sheets along the length of the room.

The sheets should be cut longer than the room.

All consecutive sheets should be installed in the **same direction**.

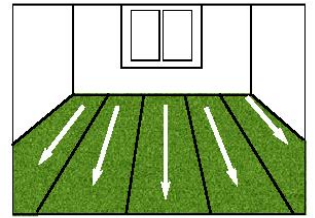

GLUING ¹

Before gluing, cut one width's edge with an edge trimmer. Install overlapping, cutting the second edge with the joint scribe (after gluing). Press the joint with lino hammer.

An acrylic conductive adhesive for linoleum should be applied to the entire subfloor with a S2 spatula. When spreading the adhesive, fold half of the sheet(s), apply the adhesive, fold back and press. Repeat this operation for the second half.

Always follow the adhesive manufacturer instructions especially regarding waiting and working time.

Ensure that the floorcovering makes good contact with the adhesive and that all air is expelled. Use a roller and roll crosswise over the floor.

¹ For more details on gluing, please refer to the separate sheet: Adhesives.

WELDING

Install sheets with a gap of approx. 0.5 mm at joint.

Start hot welding operation (and grooving) minimum 24 to 48 hours maximum after gluing. Groove a "U" shape of max. 3,5 mm width, preferably by machine.

Depth of grooving 2 mm into the thickness of the material – just over the top of the jute (max.2,5 mm for other product thickness'). Never groove Linoleum Silencio xf² to the top of foam.

Carefully clean seam totally free of residues.

The recommended welding rod temperature is about 450 °C. Use hot air welding gun fitted with 5 mm traditional hot speed weld nozzle. When welding the rod must float out slightly on both sides of the joint, on surface. Weld at approximately 2 meters per minute.

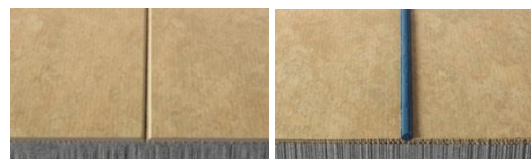

Trim the welding in two successive operations using a "quarter moon knife", Mozart knife, or similar.

The second cut should be done when the welding rod is cool down.



IMPORTANT ALWAYS do trials before starting the welding operation to adjust to existing site conditions.

If any doubts or clarifications should be needed, please contact your local Tarkett representative for further information.

AFTER INSTALLATION

IMPORTANT! Wait 48 to 72 hours before allowing any foot traffic or moving in furniture.

Protection of installation

If building work is carried out after installation, the floor should always be protected by covering it with hardboard or plywood sheeting. Masking tape must not be stuck directly to the floor.

Never subject a newly installed floorcovering to heavy wheeled traffic at an early stage, as this will force adhesive from beneath the floorcovering.

Initial site cleaning

An initial site cleaning is always recommended before the new floorcovering is commissioned.

Residual adhesive should be removed with methylated spirits and a clean cloth.

Lightly soiled floors: vacuum, sweep or damp mop the area to remove loose dirt and building dust. A combined machine is very effective for large areas (combined scrubber/dryer).

WARNING!

Do not treat the flooring with wax or polish! Applying wax, polish or similar treatment may change the products conductive behavior.

If any doubts or clarifications should be needed, please contact your local Tarkett representative for further information.