

ALKORTOP F - Mechanically fastened single ply roofing

A quick and effective roofing method for all buildings

Product

This brochure outlines the features of the Alkortop mechanically fastened roofing system: Alkortop F.

Alkortop F is a single ply reinforced membrane of thermoplastic polyolefin (TPO), a non-plasticised roof covering which provides excellent watertightness in all conditions.

With a light coloured top surface and a grey underside, it provides an attractive, smooth and robust finish, suitable at any height or roof slope.

It can be used on warm or cold roofs in a wide variety of conditions and is also well suited to ballasted or inverted main roofs.

Alkortop F, mechanically fastened roof covering is recommended for its simplicity of installation, durability and strength. When fixed, the material retains its flexibility at normal external temperatures.

Description

Alkortop F is supplied in 1050mm wide rolls and 1.2mm or 1.5mm thicknesses.

Alkortop F is supplied complete with coated metal angles, cover strips, etc., to suit the particular requirements of the scheme.

Application

The unique flexibility of Alkor membranes means that they are ideal for difficult 3-dimensional detailing, such as corners, intersections, penetrations, etc., as well as ensuring dimensional stability over large and complex roofing areas.

Alkortop F membrane is rolled out onto the clean substrate and fixed through into the substrate with proprietary fastening plates and screws. The follow-on roll is laid alongside to overlap by 100mm. The edge of the follow-on roll is hot air welded to the previous roll to provide a clean homogenous seal. (Details of typical fixing regimes are outlined overleaf).

The single skin membrane can be formed into a variety of shapes and bonded to preformed metal angles fixed directly to the substrate. This enables the most complex junctions to be sealed.

Before commencing the Alkortop F installation, the roof substrate must be free of irregularities, water, debris etc., and the loading capacity and strength of the substrate must be verified by the contractor.

Pull out tests should be carried out where the capacity and nature of the substrate is in doubt.

Alkortop F - Reinberg



Typically, Alkortop F may be installed as follows:

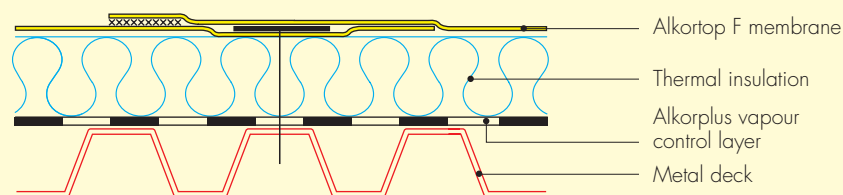

Warm Roof

Profiled metal sheets must be at least 0.7mm thick and be designed, manufactured and installed to current design criteria and statutory requirements.

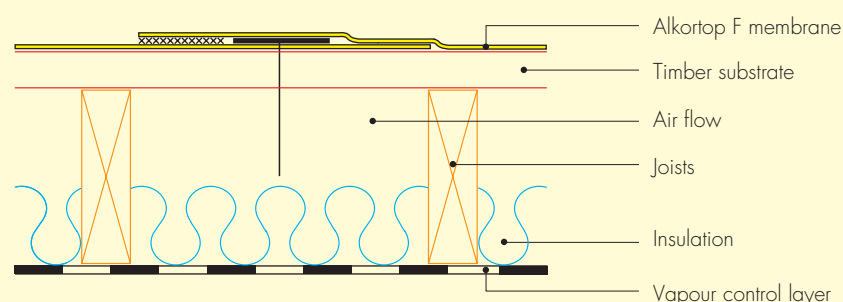

Cold Roof

Fixings are not required to penetrate through to the main structure in normal conditions although they must extend a minimum 2mm beyond the substrate.

The timber substrate must be 25mm t&g treated timber or 22mm plywood and comply with BS 5268:Pt2:1991. Variations to this must be checked with Alkor's technical department.

All treated timber in contact with Alkortop must be treated with salt based preservative and be free of splinters, ruts, distortion, etc... Nail heads must be punched below the surface of the substrate so that the finished surface has no protrusions. Jointing tolerances between substrate panels must not exceed 3mm.

Figure 1: Typical fixing

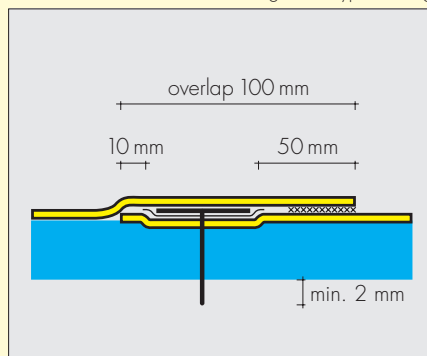

Protection Layer

Where rough substrate surfaces cannot be avoided, an Alkorplus protective fleece 81009 should be loose laid over the substrate to ensure that no damage occurs to the Alkortop membrane.

Separation layer on fresh bitumen

Alkortop roofing membranes are free of plasticiser and therefore do not require any separation layer when installed on mineral wool, polystyrene or polyurethane. On freshly produced bituminous substrates (e.g. bitumen faced insulation) a 300 g/m² Alkorplus polyester separation layer is required.

Thermal Insulation

The type and location of the thermal insulation is a fundamental consideration of any roof specification; to ensure stability, compliance with Building Regulations, and to avoid condensation build-up.

Thermal insulation located directly below Alkortop F must be dimensionally stable, inflammable and able to withstand loads of 0.06N/mm².

Where regular access is required over the Alkortop roof, obtain details of the compressive strength of the insulation layer. Insulation boards in two or more layers must be staggered and tightly butted. Where regular access is required, walkways are recommended.

The use of thermal insulation must be subject to approval by the specific insulation manufacturer and our technical department will be pleased to offer advice on appropriate materials.

Vapour Control Layer

Depending on the building use and roof construction, an Alkorplus 81012 vapour control layer should be provided on the warm side of the roof build up. We recommend that condensation calculations be carried out to ensure the correct placement of the insulation and the Alkorplus vapour control layer.

To achieve a complete vapour check, the Alkorplus 81012 must be sealed at all roof penetrations and abutments, etc... Experience shows that proprietary fixings through the vapour control layer are self-sealing, maintaining the integrity of the vapour check.

Alkortop F roofing membrane				colour 91748
Thickness	Width	Weight	Roll length	Roll weight
1,2mm	1050mm	approx. 1,37kg/m ²	25m	approx. 36kg
1,5mm	1050mm	approx. 1,71kg/m ²	20m	approx. 36kg

Workmanship

Please note that Alkortop F is supplied complete with accessories, angles, etc... The preformed metal angles are known as Alkormetal. Do not use non-proprietary products with the Alkortop membrane.

Laying out the Roof

A roll of Alkortop F is set out and rolled out over the roof. Fixing plates are laid out along the edge, making sure that these are at least 10mm from the edge and at least 200mm apart. The roofing installer then screws through the fixing plate, through the membrane and into the substrate (see fig 1).

The follow-on layer is positioned to ensure a minimum 100mm overlap. The installer then hot air welds the overlap. All edges must be clean and dry to ensure a perfect homogenous bond. For further details refer to the Alkortop welding guide.

Fixing

A wind load calculation in accordance with BS 6399:Pt2:1997 must be carried out to assess the type, size and number of fixings. Alkortop F must be continuously fixed at roof edges, upstands and abutments, (and valleys less than 174°). At parapets we recommend either the overlap fixing details shown in fig 2 or the use of a proprietary Alkormetal angle, as shown in fig 3. Both details ensure that a watertight junction is formed in a neat, straightforward manner.

Upstands

To form upstands with Alkor 's proprietary preformed angles, the coated Alkormetal is fixed through to the substrate at 200mm intervals, ending no more than 50mm from Alkormetal joints. The Alkortop F membrane is laid to overlap and is hot air welded to the Alkormetal to form a sealed and secure edge. There must be a 5mm gap between adjoining Alkormetal sections to allow for thermal movement. Before laying the Alkortop F membrane, Alkor separating tape is laid over the open Alkormetal joint and a strip of Alkortop, 200mm wide, is welded over the top to bond to the metal on each side. The Alkortop F roofing is then laid over as normal, (see fig 4). The upper edge of every upstand must be watertight and windtight. These are critical details and our technical department will be pleased to offer advice on the correct specification, detailing and workmanship.

Table 2: Alkortop 35085 Product data

Product Data	Testing to DIN 16726	Requirements	Average production values		Units
			1.2mm	1.5mm	
Tensile strength membrane	5.6 C - VI	L >800 T >800	867 842	1140 956	N/50mm N/50mm
Elongation	5.6 C - VI	L >400 T >400	590 620	650 650	% %
Tear strenght	5.8.1	L >120 T >120	179 200	172 207	N N
Puncture tear strenght	UEAtc UEAtc	L >250 T >250	450 380	470 395	N N
Lamination strenght	5.9	>100	210	270	N/50mm
Shrinkage (6h/80°)	5.13	ILI >0,5 ITI >0,5	- 0,2 - 0,2	- 0,1 - 0,4	% %
Cold crack performance (tested at -40°C)	5.14	no perforation	no perforation	no perforation	-
Vapour diffusion resistance (μ)	5.15	-	135.000	135.000	-

Figure 2

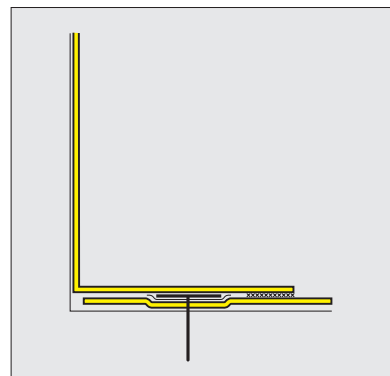

Figure 3

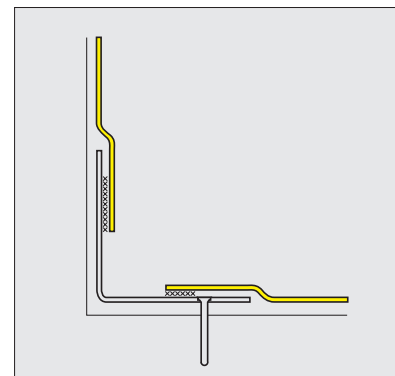
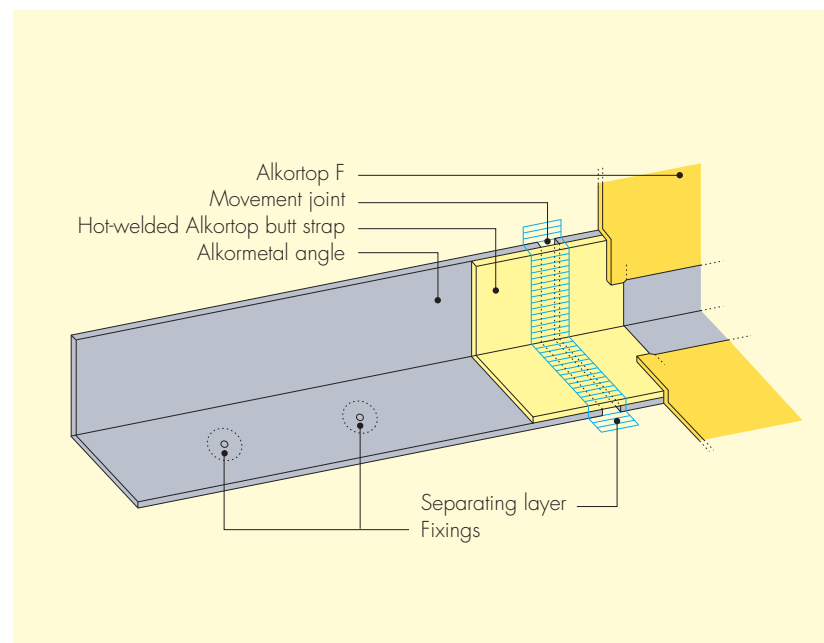

Figure 4: Typical setting out



Materials/Components

To bond Alkortop F to roof penetrations and edge details, there is a range of system components available, to which Alkortop F can be hot air welded, to provide a complete seal. Where an homogenous seal cannot be provided, we recommend the use of upstand details and pipe collar flashings. Where possible, there should be at least 300mm distance between upstands, penetrations, abutments, edges, etc., to ensure that adjacent Alkormetal angles can be positioned without overlapping.

Parapets

Alkortop F must be hot air welded to proprietary Alkormetal parapet cappings and trims. Joints in Alkormetal must be sealed with a strip of separating tape and covered with a welded butt strap of Alkortop, (as described on page 4), before installing the Alkortop F upstand details.

Water outlets fixings

Water outlets, as well as air vents, etc., need to be mechanically fixed to the substrate.

Rainwater Outlets

The position of internal outlets and the direction of falls should ensure that rainwater is directed off the roof area as efficiently as possible, (see Detail 1). Alkormetal trims provide a straight-forward and effective detail.

Eaves

Roof edges must be sealed to prevent wind uplift and to seal the structure from water ingress. Fix proprietary Alkormetal flashings, (as Detail 2), and hot weld Alkortop F to the surface to provide a minimum 150mm overlap. Flashings are suitable for profiled metal roofing as well as for the standard eaves as shown.

Finish roof sections before continuing

A roof section should be completely finished incl. details before installing membrane on another part of the roof, as welding on exposed Alkortop membranes can involve time-consuming cleaning.

Technical Guidance

Please consult Alkor's Technical Design Manual for additional detail drawings or consult our technical department for assistance.

Detail 1: Typical outlet

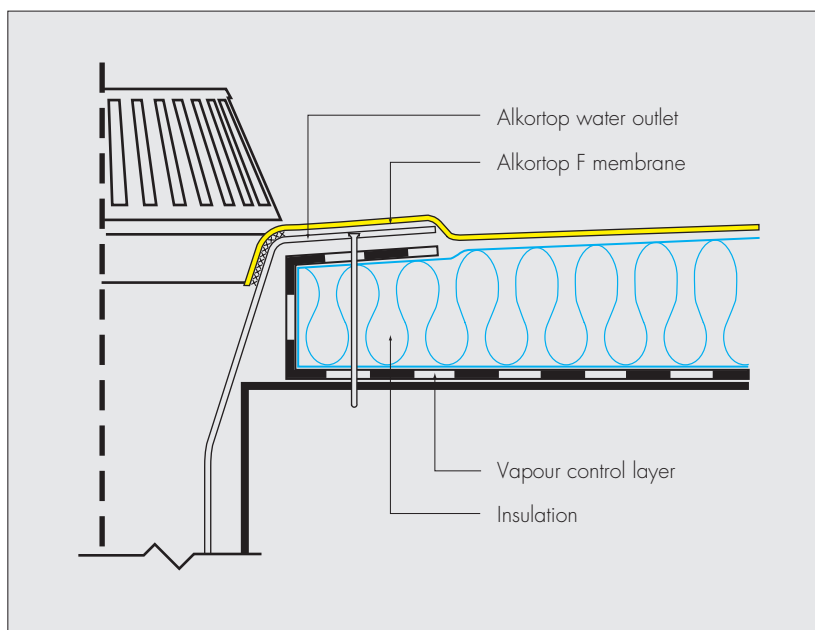

Detail 2: Typical eaves

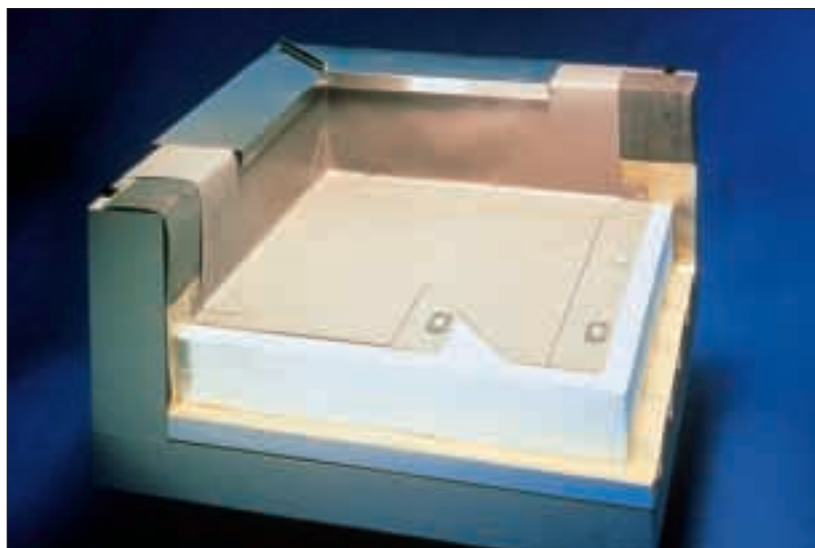
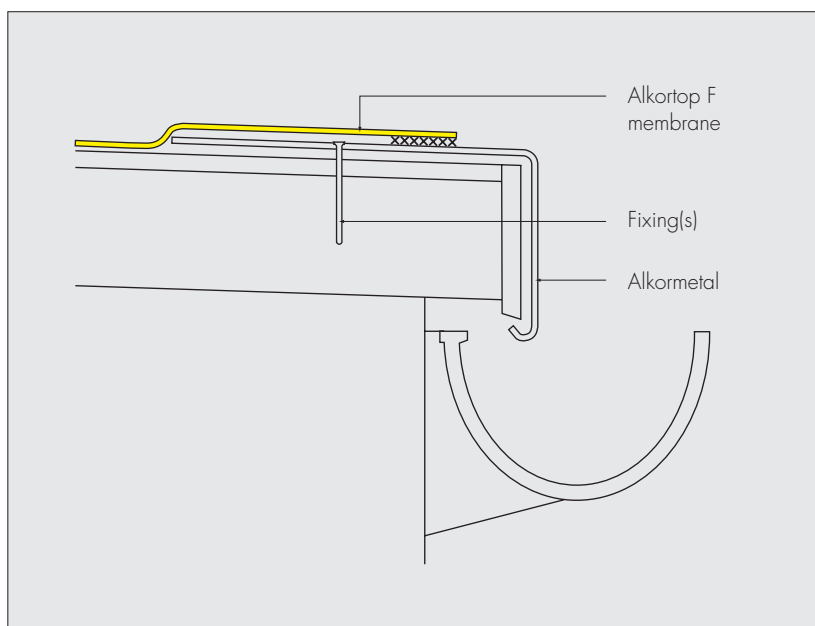

Alkortop F warm roof

General Comments

Please ensure compliance with the following guidelines:

- BBA
- Building Regulations
- BS 6229 1982 Flat roofs with continuous supported coverings
- BS 6399 Wind Load Calculation
- all other current statutory regulations, good practice guidelines, codes of practice and relevant directives
- the detailed product information and instructions for execution of particular details issued by **RENOLIT Great Britain LTD** concerning Alkortop F
- the installation instructions issued by manufacturers or suppliers of other materials and accessories used in the construction of the roof
- Health and Safety regulations, CDM Regulations, etc
- Condensation risk analysis

Compatibility

- Alkortop membranes must not come into contact with Alkorplan or Alkorflex membranes
- the surface to receive Alkortop F must be clean, dry and free of irregularities, sharp edges, etc., such that the membrane cannot be damaged
- all treated timber in contact with Alkortop F must contain only salt based preservative
- Store rolls parallel and in original packing where possible. Do not stack in cross form nor put weight onto individual rolls.

GUARANTEE OF QUALITY

Over 140 million square metres of Alkor Waterproofing Membrane have been laid worldwide, over the past 25 years. In the UK, Alkor have been operating since 1981, and have yet to receive a claim for failure of membrane or system. This document sets out the Guarantees and Assurances that support Alkor membranes and accessories.



RENOLIT WATERPROOFING is Approved to ISO 9001 for Research, Production and Distribution of Alkor waterproofing membranes.



Alkor Roofing Membranes are assessed by The British Board of Agreement for a life in excess of 25 years.



Alkor Technicians inspect installations and, in conjunction with the approved contractors, issue Certificates of Assurance, covering Materials, Accessories, Systems and Installation where required.

This manufacturer's instruction manual applies to the mechanical fixing of Alkortop membrane on different substrates in the U.K. For the loose laying of Alkortop membranes, there is a specific installation system developed which should be referred to for correct detailing. The information contained in this brochure is based on current knowledge at the time of writing and may be subject to change without notification. Nothing contained herein may be taken as permission to use or apply our products without observing existing patents, certificates, legal regulations, national and local rules and guidelines, technical approvals or technical specifications or the rules and practices of good workmanship for his/her profession.

The purchaser should verify whether import, advertising, packaging, labelling, composition, possession, ownership and the use of our products or the commercialisation of them are subject to special territorial rules. He/she is the sole person responsible for notifying and advising the end user. Because not all conditions are described herein, our technical department must be consulted on specifics of each scheme. Where our technical department have not been consulted, we cannot accept any liability for difficulties and faults that might arise in conception, design, safety, execution or maintenance. In the case of negligence on the part of the purchaser, specifically with reference to rules, regulations and duties, we will disclaim all responsibility.

Full details of ALKORTOP chemical stability results are available on request.

November 2002

RENOLIT Great Britain LTD

Axis 5
Rhodes Way
WATFORD, HERTS
WD24 4TN
Great Britain
Tel: 01923/24 95 11
Fax: 01923/22 74 27



Mechanically fastened Polyolefin roofing

BENEFITS

- **Quick and economical to lay**
- **Safe and clean to install**
- **Flexible**
- **Environmentally safe**
- **Non-degradable**
- **Puncture resistant**
- **Resistant to common air pollutants**
- **Highly chemical resistant**
- **FAA Fire Rating**
- **Suitable for roof planting**
- **Recyclable**
- **Manufacturing unit assessed to ISO 9001**

Detail 1: Typical external abutment

